

SERIES: HNTC Hydraulic Nuts



HNTC Hydraulic Nuts are used in direct replacement of the existing conventional nut. They allow accurate loading of the bolt, and the load is then permanently retained by means of a load locking collar.

PAL PURE AXIAL LOADING

TensionPro hydraulic nuts allow bolts to be loaded with an accurate force that is directly proportional to the pressure applied to the tool.

NO FRICTION bolt tightening for an accurate and repeatable bolt tightening method.

The tensioner load or force is easily calculated:

$$F = (P \times A) / 10,000$$

| | |
|--------------------|----------------------|
| Tensioner Force | F [kN] |
| Tool Pressure Area | A [mm ²] |
| Pressure | P [kN] |

OPTIONS

- Thread sizes from M20 to M200
- Imperial or metric
- Designs to suit special load requirements
- Special threads
- Temperatures from 20° to 200°C
- Subsea use
- Long stroke designs
- Single or twin ports
- Corrosion resistant plating
- Stainless steel versions

SAFE AND RELIABLE

- CE marked
- Safe over-stroke device
- Max stroke indicator
- Pressure Test Certification
- Full colour operating and safety manual
- Long life performance

LATEST TECHNOLOGY

- Latest seal technology
- High cycle life
- Optimised load to weight ratio
- Integrated system with TensionPro pumps and hoses

PROCESS IMPROVEMENT

HNTC Hydraulic nuts are quick and simple to use. Installed by hand in minutes, multiple nuts are harnessed together to give **IMPROVED SPEED** for the bolt tightening process. The even joint compression ensures uniform bolt loading and gasket compression that gives superior bolted joint performance.

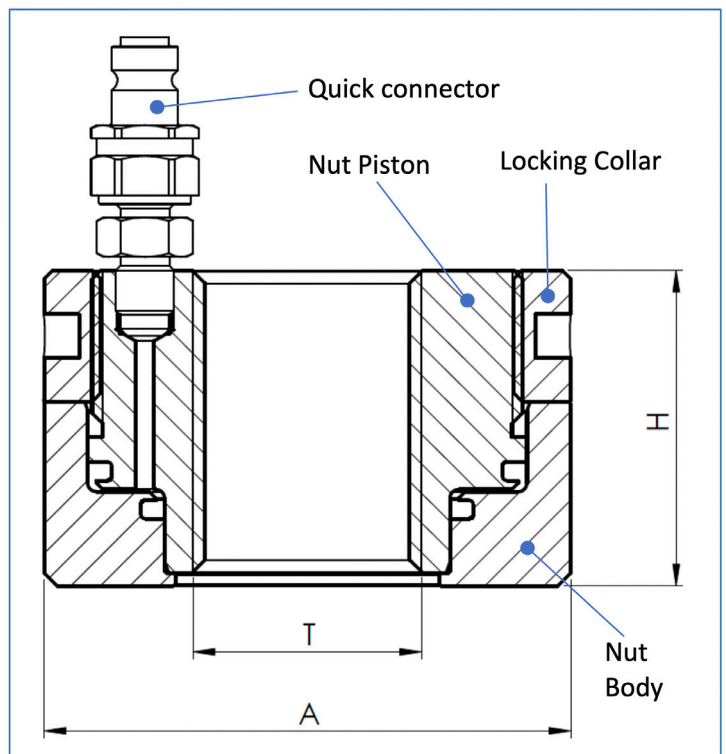

SERIES: HNTC Hydraulic Nuts

HTNTC-25 Range - MAX 2500 bar pressure

| Part Number | | Bolt Thread Size | | Nut Maximum Load | | Pressure Area | Nut OD | Nut Height | Nut Stroke | Weight |
|--------------|--------------|------------------|----------|------------------|-------|-----------------|--------|------------|------------|--------|
| Metric | Imperial | Metric | Imperial | kN | tonf | HPA | A | H | | |
| | | | | | | mm ² | mm | mm | mm | kg |
| HNTC-25-M22 | HNTC-25-0875 | M22 | 7/8 | 152 | 15.2 | 607 | 55 | 44 | 5 | 0.7 |
| HNTC-25-M24 | HNTC-25-1000 | M24 | 1 | 176 | 17.7 | 705 | 58 | 45 | 5 | 0.8 |
| HNTC-25-M27 | HNTC-25-1125 | M27 | 1 1/8 | 230 | 23.1 | 919 | 60 | 46 | 5 | 0.8 |
| HNTC-25-M30 | - | M30 | - | 280 | 28.1 | 1121 | 66 | 48 | 5 | 1.0 |
| HNTC-25-M33 | HNTC-25-1250 | M33 | 1 1/4 | 312 | 31.3 | 1248 | 71 | 52 | 6 | 1.3 |
| HNTC-25-M36 | HNTC-25-1375 | M36 | 1 3/8 | 368 | 36.9 | 1470 | 77 | 56 | 6 | 1.6 |
| HNTC-25-M39 | HNTC-25-1500 | M39 | 1 1/2 | 390 | 39.2 | 1561 | 80 | 58 | 6 | 1.7 |
| HNTC-25-M42 | HNTC-25-1625 | M42 | 1 5/8 | 448 | 45.0 | 1793 | 85 | 61 | 6 | 2.0 |
| HNTC-25-M45 | HNTC-25-1750 | M45 | 1 3/4 | 522 | 52.4 | 2090 | 92 | 64 | 6 | 2.5 |
| HNTC-25-M48 | HNTC-25-1875 | M48 | 1 7/8 | 589 | 59.1 | 2357 | 97 | 68 | 8 | 3.0 |
| HNTC-25-M52 | HNTC-25-2000 | M52 | 2 | 703 | 70.6 | 2813 | 105 | 70 | 8 | 3.6 |
| HNTC-25-M56 | HNTC-25-2250 | M56 | 2 1/4 | 812 | 81.5 | 3248 | 113 | 72 | 8 | 4.2 |
| HNTC-25-M60 | - | M60 | - | 945 | 94.8 | 3779 | 122 | 74 | 8 | 5.1 |
| HNTC-25-M64 | HNTC-25-2500 | M64 | 2 1/2 | 1070 | 107.4 | 4282 | 129 | 80 | 8 | 6.1 |
| HNTC-25-M68 | HNTC-25-2750 | M68 | 2 3/4 | 1222 | 122.7 | 4888 | 137 | 84 | 10 | 7.3 |
| HNTC-25-M72 | HNTC-25-3000 | M72 | 3 | 1384 | 138.9 | 5536 | 146 | 88 | 10 | 8.7 |
| HNTC-25-M80 | HNTC-25-3250 | M80 | 3 1/4 | 1738 | 174.4 | 6950 | 162 | 92 | 10 | 11.2 |
| HNTC-25-M90 | HNTC-25-3500 | M90 | 3 1/2 | 2236 | 224.4 | 8945 | 184 | 96 | 10 | 15.1 |
| HNTC-25-M95 | HNTC-25-3750 | M95 | 3 3/4 | 2509 | 251.8 | 10037 | 194 | 100 | 10 | 17.5 |
| HNTC-25-M100 | HNTC-25-4000 | M100 | 4 | 2798 | 280.8 | 11191 | 204 | 105 | 15 | 20.3 |
| HNTC-25-M110 | HNTC-25-4500 | M110 | 4 1/2 | 3422 | 343.5 | 13689 | 225 | 110 | 15 | 26.0 |
| HNTC-25-M125 | HNTC-25-5000 | M125 | 5 | 4477 | 449.3 | 17906 | 257 | 125 | 15 | 38.6 |
| HNTC-25-M140 | HNTC-25-5500 | M140 | 5 1/2 | 5672 | 569.3 | 22689 | 289 | 140 | 15 | 54.8 |
| HNTC-25-M150 | HNTC-25-6000 | M150 | 6 | 6548 | 657.2 | 26192 | 311 | 150 | 15 | 68.2 |

HTNTC-15 Range - MAX 1500 bar pressure

| Part Number | | Bolt Thread Size | | Nut Maximum Load | | Pressure Area | Nut OD | Nut Height | Nut Stroke | Weight |
|--------------|--------------|------------------|----------|------------------|-------|-----------------|--------|------------|------------|--------|
| Metric | Imperial | Metric | Imperial | kN | tonf | HPA | A | H | | |
| | | | | | | mm ² | mm | mm | mm | kg |
| HNTC-15-M22 | HNTC-15-0875 | M22 | 7/8 | 152 | 15.2 | 1011 | 57 | 44 | 5 | 0.7 |
| HNTC-15-M24 | HNTC-15-1000 | M24 | 1 | 176 | 17.7 | 1175 | 60 | 45 | 5 | 0.8 |
| HNTC-15-M27 | HNTC-15-1125 | M27 | 1 1/8 | 230 | 23.1 | 1531 | 65 | 46 | 5 | 1.0 |
| HNTC-15-M30 | - | M30 | - | 280 | 28.1 | 1869 | 73 | 48 | 5 | 1.3 |
| HNTC-15-M33 | HNTC-15-1250 | M33 | 1 1/4 | 312 | 31.3 | 2081 | 78 | 52 | 6 | 1.6 |
| HNTC-15-M36 | HNTC-15-1375 | M36 | 1 3/8 | 368 | 36.9 | 2450 | 85 | 56 | 6 | 2.0 |
| HNTC-15-M39 | HNTC-15-1500 | M39 | 1 1/2 | 390 | 39.2 | 2602 | 88 | 58 | 6 | 2.2 |
| HNTC-15-M42 | HNTC-15-1625 | M42 | 1 5/8 | 448 | 45.0 | 2989 | 93 | 61 | 6 | 2.6 |
| HNTC-15-M45 | HNTC-15-1750 | M45 | 1 3/4 | 522 | 52.4 | 3483 | 101 | 64 | 6 | 3.2 |
| HNTC-15-M48 | HNTC-15-1875 | M48 | 1 7/8 | 589 | 59.1 | 3928 | 107 | 68 | 8 | 3.8 |
| HNTC-15-M52 | HNTC-15-2000 | M52 | 2 | 703 | 70.6 | 4688 | 116 | 70 | 8 | 4.6 |
| HNTC-15-M56 | HNTC-15-2250 | M56 | 2 1/4 | 812 | 81.5 | 5413 | 125 | 72 | 8 | 5.5 |
| HNTC-15-M60 | - | M60 | - | 945 | 94.8 | 6299 | 134 | 74 | 8 | 6.5 |
| HNTC-15-M64 | HNTC-15-1500 | M64 | 2 1/2 | 1070 | 107.4 | 7136 | 142 | 80 | 8 | 7.9 |
| HNTC-15-M68 | HNTC-15-2750 | M68 | 2 3/4 | 1222 | 122.7 | 8147 | 152 | 84 | 10 | 9.5 |
| HNTC-15-M72 | HNTC-15-3000 | M72 | 3 | 1384 | 138.9 | 9226 | 161 | 88 | 10 | 11.2 |
| HNTC-15-M80 | HNTC-15-3250 | M80 | 3 1/4 | 1738 | 174.4 | 11584 | 179 | 92 | 10 | 14.5 |
| HNTC-15-M90 | HNTC-15-3500 | M90 | 3 1/2 | 2236 | 224.4 | 14909 | 203 | 96 | 10 | 19.5 |
| HNTC-15-M95 | HNTC-15-3750 | M95 | 3 3/4 | 2509 | 251.8 | 16728 | 215 | 100 | 10 | 22.8 |
| HNTC-15-M100 | HNTC-15-4000 | M100 | 4 | 2798 | 280.8 | 18652 | 226 | 105 | 15 | 26.4 |
| HNTC-15-M110 | HNTC-15-4500 | M110 | 4 1/2 | 3422 | 343.5 | 22815 | 250 | 110 | 15 | 34.0 |
| HNTC-15-M125 | HNTC-15-5000 | M125 | 5 | 4477 | 449.3 | 29844 | 285 | 125 | 15 | 50.2 |
| HNTC-15-M140 | HNTC-15-5500 | M140 | 5 1/2 | 5672 | 569.3 | 37815 | 321 | 140 | 15 | 71.6 |
| HNTC-15-M150 | HNTC-15-6000 | M150 | 6 | 6548 | 657.2 | 43653 | 345 | 150 | 15 | 88.7 |